

ELECTRIC POWERED HOIST

MODEL No.	Description or Type	WEIGHT
180-030	Single ϕ - 120/240 Dual Voltage	106 lbs./48 Kg.
180-031	Single ϕ - 240 Volt	106 lbs./48 Kg.
180-032	Single ϕ - 120 Volt	102 lbs./46 Kg.
Uses:	5/16 6x19 Class Wire Rope -	#600004
Or:	5/16 6x31 Class Wire Rope -	#600001

Note: Assembly Dimensions

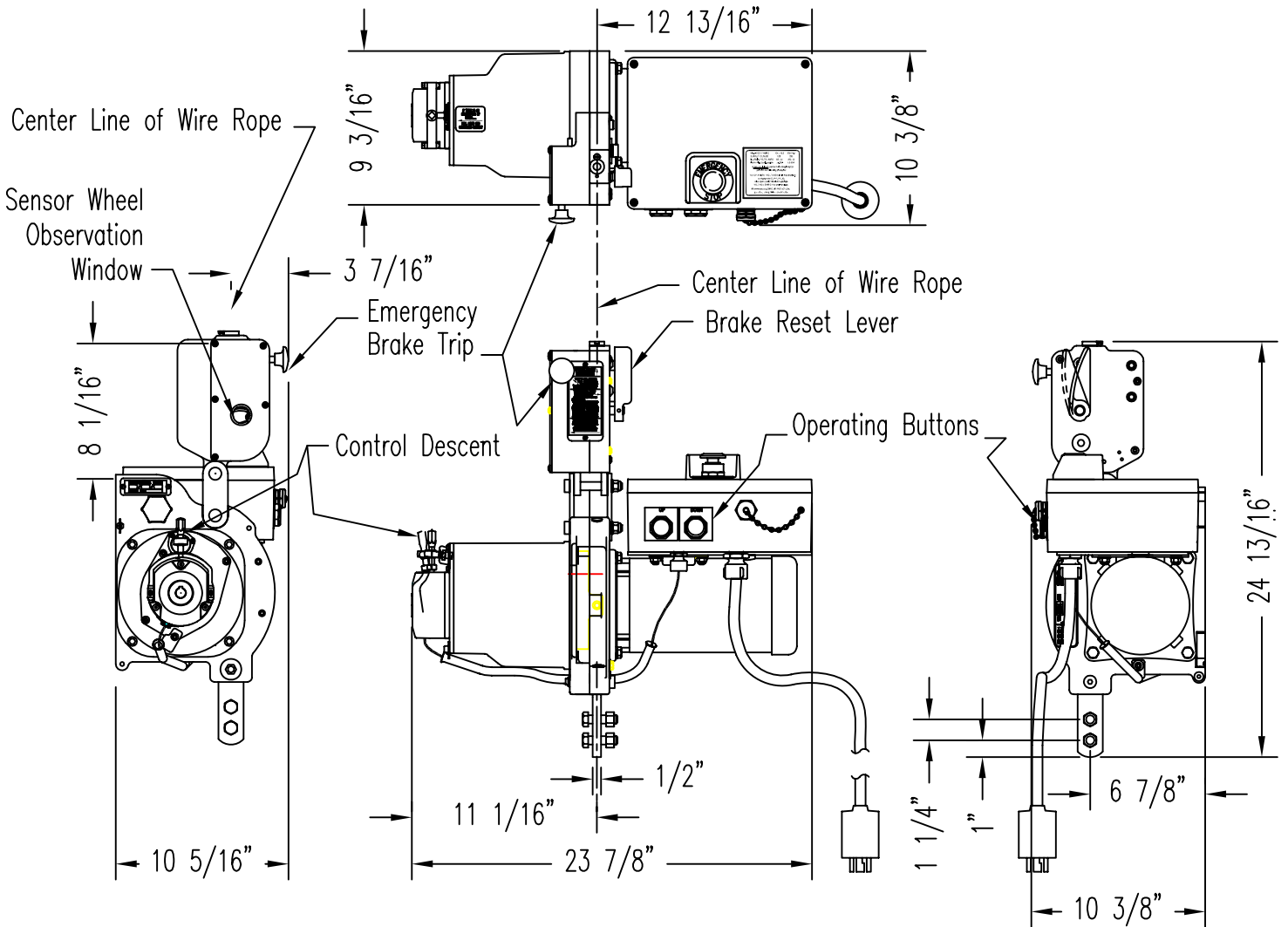
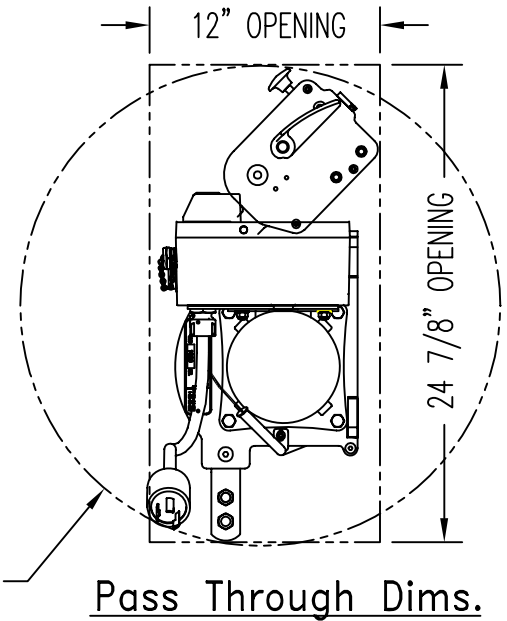

GENERAL NOTES:

- 1) CAPACITY = 1000#
- 2) HOIST SPEED = 35 FPM
- 3) POWER SUPPLY = 120/240 VAC, 1 PH, 60 HZ